



# InfiniBand Trade Association Integrators' List

May 2021



# IBTA InfiniBand Integrators' List May 2021

Manufacturer	Description	Model	Type	Speed	FW	SW
NVIDIA	BlueField®-2 E-Series DPU 100GbE/EDR VPI Dual-Port QSFP56, PCIe Gen4 x16	MBF2M516A-EENOT	HCA	EDR	12.27.1016	MLNX_OFED_LINUX 5.3-1.0.0.1
NVIDIA	ConnectX®-5 VPI, EDR IB (100Gb/s) and 100GbE Dual-port QSFP28, PCIe4.0 x16	MCX556A-EDAT	HCA	EDR	16.27.2008	MLNX_OFED_LINUX 5.3-1.0.0.1
NVIDIA	ConnectX®-6 VPI adapter card, HDR IB (200Gb/s) and 200GbE, dual-port QSFP56, Socket Direct 2x PCIe3.0 x16	MCX654106A-HCAT	HCA	HDR	20.27.1016	MLNX_OFED_LINUX 5.3-1.0.0.1
NVIDIA	Switch-IB 2 based EDR InfiniBand 1U Switch, 36 QSFP28 ports, x86 dual core	MSB7800-ES2F	Switch	EDR	15.2007.0300	3.9.2400
NVIDIA	NVIDIA® Quantum(TM) HDR InfiniBand Switch, 40 QSFP56 ports, 2 Power Supplies (AC), x86 dual core	MQM8700-HS2F	Switch	HDR	27.2007.0300	3.9.2400
NetApp	Dual Controllers iSER EDR Target	E5700	iSER Target	EDR	8.7	11.70R3
<b>Software</b>						
<b>Software</b>	<b>Versions</b>	<b>Diagnostic Software</b>				
Operating System	<a href="#">Cent OS 8.3.2011</a>	<a href="#">ibutils2</a>		<a href="#">MLNX OFED 5.0-2.1.8.0</a>		
Mellanox OFED	<a href="#">MLNX OFED 5.3-1.0.0.1</a>	<a href="#">Compliance Test Suite v 1.0.67</a>				
Open MPI	<a href="#">Open MPI 4.1.1</a>					
Open MPI	<a href="https://www.open-mpi.org/doc/">https://www.open-mpi.org/doc/</a>					
Benchmark	<a href="#">Intel MPI Benchmarks</a>	<b>Benchmarks Performed</b>				
Test Plan	<a href="#">Software Forge IBTA MOI Suite</a>	PingPong		Gather		
Duration	2-5 Minutes	PingPing		Gatherv		
		Sendrecv		Scatter		
		Exchange		Scatterv		
<b>Conditions for Passing Testing</b>		Allreduce		Alltoall		
Link Width	Link width is @ expected width - i.e. 1x,4x, etc	Reduce		Alltoallv		
Link Speed	Link speed is @ expected speed - e.g. 100 GbE	Reduce_scatter		Bcast		
Errors	There must be no errors recorded during any test phases	Allgather		Barrier		
MPI Test	The MPI Benchmark must run to completion					

NVIDIA HCAs		Model	MBF2M516A-EENOT	MCX556A-EDAT	MCX654106A-HCAT
		Date	2021-05-24-01	2021-05-10-01	2021-05-20-01
		Firmware Version	24.30.1004	16.30.1004	20.30.1004
		Overall Results	Pass	Pass	Pass
Test Class	Name	Number	Results	Results	Results
Management	ResponseTimeValue	C13-013	Pass	Pass	Pass
	ResponseTimeValue - Single Packet	C13-014_01	Pass	Pass	Pass
Subnet Management	No M_Key Checking	C14-015	Pass	Pass	Pass
	M_Key Checking - SubnGet	C14-016_Get	Pass	Pass	Pass
	M_Key Checking - SubnSet	C-14-016_Set	Pass	Pass	Pass
	M_Key Lease Period Timer - Part 1	C-14-017	Pass	Pass	Pass
	M_Key Lease Period Timer - Part 2		Pass	Pass	Pass
	M_Key Lease Period Timer - Part 3		Pass	Pass	Pass
	M_Key Lease Period Timer - Part 4		Pass	Pass	Pass
	M_Key Lease Period Timer - Part 5		Pass	Pass	Pass
	M_Key Violation Counter	C14-018	Pass	Pass	Pass
	M_Key Components in NVRAM	C14-023	Pass	Pass	Pass
	Node Description	C14-024#02	Pass	Pass	Pass
	NodeInfo	C14-024#03	Pass	Pass	Pass
	GUIDInfo	C14-024#05	Pass	Pass	Pass
	PortInfo xCA - Part 1	C14-024#06_CA_01	Pass	Pass	Pass
	PortInfo xCA - Part 2	C14-024#06_CA_02	Pass	Pass	Pass
	PortInfo xCA - Part 3	C14-024#06_CA_03	Pass	Pass	Pass
	PortInfo xCA - Part 4	C14-024#06_CA_04	N/A	N/A	N/A
	PortInfo xCA - Part 5	C14-024#06_CA_05	N/A	N/A	N/A
	PortInfo xCA - Part 6	C14-024#06_CA_06	Pass	Pass	Pass
	PortInfo LocalPortNum	C14_024_06_LocalPortNum	Pass	Pass	Pass
	P_Key - Part 1	C14-024#07_01	Pass	Pass	Pass
	SLToVL Mapping - Part 1	C14-024#08_01	Pass	Pass	Pass
	SLToVL Mapping - Part 2	C14-024#08_02	N/A	N/A	N/A
	VLArbitration - CA	C14-024#09_xCA	Pass	Pass	Pass
LedInfo	C14-024#15	Pass	Pass	Pass	
Subnet Manager	SMInfo - Supported	C14-024#13-01	Pass	Pass	Pass
	SMInfo - Unsupported	C14-024#13-03	N/A	N/A	N/A
Subnet Administration	SubnAdminGet(ServiceRecord)	C15-0.1.012#15	Pass	Pass	Pass
	SubnAdminGet(PathRecord)	C15-0.1.012#17.01	Pass	Pass	Pass
	SubnAdminGet(PathRecord) - Part 1	C15-0.1-012#17.02 - Part 1	Pass	Pass	Pass
	SubnAdminGet(PathRecord) - Part 2	C15-0.1-012#17.02 - Part 2	Pass	Pass	Pass
	SubnAdminGet(PathRecord) - Part 3	C15-0.1-012#17.02 - Part 3	Pass	Pass	Pass
	SM-SA Validation	SM-SA Validation	Pass	Pass	Pass



<b>NVIDIA Switches</b>		<b>Model</b>	<b>MQM8700-HSF</b>	<b>MSB7800-ES2F</b>
		<b>Date</b>	2021-05-12-01	2021-06-15-01
		<b>Firmware Version</b>	27.2008.2500	15.2008.2402
		<b>Overall Results</b>	<b>Pass</b>	<b>Pass</b>
<b>Test Class</b>	<b>Name</b>	<b>Number</b>	<b>Results</b>	<b>Results</b>
<b>Management</b>	ResponseTimeValue	C13-013	<b>Pass</b>	<b>Pass</b>
	ResponseTimeValue - Single Packet	C13-014_01	<b>Pass</b>	<b>Pass</b>
<b>Subnet Management</b>	No M_Key Checking	C14-015	<b>Pass</b>	<b>Pass</b>
	M_Key Checking - SubnGet	C14-016_Get	<b>Pass</b>	<b>Pass</b>
	M_Key Checking - SubnSet	C-14-016_Set	<b>Pass</b>	<b>Pass</b>
	M_Key Lease Period Timer - Part 1	C-14-017	<b>Pass</b>	<b>Pass</b>
	M_Key Lease Period Timer - Part 2		<b>Pass</b>	<b>Pass</b>
	M_Key Lease Period Timer - Part 3		<b>Pass</b>	<b>Pass</b>
	M_Key Lease Period Timer - Part 4		<b>Pass</b>	<b>Pass</b>
	M_Key Lease Period Timer - Part 5		<b>Pass</b>	<b>Pass</b>
	M_Key Violation Counter	C14-018	<b>Pass</b>	<b>Pass</b>
	M_Key Components in NVRAM	C14-023	<b>Pass</b>	<b>Pass</b>
	Node Description	C14-024#02	<b>Pass</b>	<b>Pass</b>
	NodeInfo	C14-024#03	<b>Pass</b>	<b>Pass</b>
	SwitchInfo - RO	C14-024#04_SW_01	<b>Pass</b>	<b>Pass</b>
	SwitchInfo - Part 1	C14-024#04_SW_02	<b>Pass</b>	<b>Pass</b>
	SwitchInfo - Part 2	C14-024#04_SW_03	<b>Pass</b>	<b>Pass</b>
	GUIDInfo	C14-024#05	<b>Pass</b>	<b>Pass</b>
	PortInfo Switch - Part 1	C14-024#06_SW_01	<b>Pass</b>	<b>Pass</b>
	PortInfo Switch - Part 2	C14-024#06_SW_02	<b>Pass</b>	<b>Pass</b>
	PortInfo Switch - Part 3	C14-024#06_SW_03	<b>N/A</b>	<b>N/A</b>
	PortInfo Switch - Part 4	C14-024#06_SW_04	<b>Pass</b>	<b>Pass</b>
	PortInfo Switch - Part 5	C14-024#06_SW_05	<b>Pass</b>	<b>Pass</b>
PortInfo Switch - Part 6	C14-024#06_SW_06	<b>Pass</b>	<b>Pass</b>	
PortInfo Switch - Part 7	C14-024#06_SW_07	<b>Pass</b>	<b>Pass</b>	
PortInfo LocalPortNum	C14_024_06_LocalPortNum	<b>Pass</b>	<b>Pass</b>	

<b>NVIDIA Switches</b>		<b>Model</b>	<b>MQM8700-HSF</b>	<b>MSB7800-ES2F</b>
		<b>Date</b>	2021-05-12-01	2021-06-15-01
		<b>Firmware Version</b>	27.2008.2500	15.2008.2402
		<b>Overall Results</b>	<b>Pass</b>	<b>Pass</b>
<b>Test Class</b>	<b>Name</b>	<b>Number</b>	<b>Results</b>	<b>Results</b>
<b>Subnet Management Continued</b>	P_Key - Part 1	C14-024#07_01	<b>Pass</b>	<b>Pass</b>
	P_Key - Part 2	C14-024#07_02	<b>N/A</b>	<b>N/A</b>
	P_Key - Part 3	C14-024#07_03	<b>Pass</b>	<b>Pass</b>
	P_Key - Part 4	C14-024#07_04	<b>Pass</b>	<b>Pass</b>
	P_Key - Part 5	C14-024#07_05	<b>Pass</b>	<b>Pass</b>
	SLToVL Mapping - Part 3	C14-024#08_03	<b>Pass</b>	<b>Pass</b>
	SLToVL Mapping - Part 4	C14-024#08_04	<b>N/A</b>	<b>N/A</b>
	SLToVL Mapping - Part 5	C14-024#08_05	<b>Pass</b>	<b>Pass</b>
	VLArbtration - SW	C14-024#09_SW	<b>Pass</b>	<b>Pass</b>
	LFT - Unsupported	C14-024#10_01	<b>N/A</b>	<b>N/A</b>
	LFT Supported - Valid Ports	C14-024#10_02	<b>Pass</b>	<b>Pass</b>
	LFT Supported - Invalid Ports	C14-024#10_03	<b>Pass</b>	<b>Pass</b>
	Random Forwarding Table	C14-024#11	<b>Pass</b>	<b>Pass</b>
	Mcast Forwarding Table	C14-024#12	<b>Pass</b>	<b>Pass</b>
LedInfo	C14-024#15	<b>Pass</b>	<b>Pass</b>	
<b>Subnet Manager  Subnet Administration</b>	SMInfo - Supported	C14-024#13-01	<b>Pass</b>	<b>Pass</b>
	SMInfo - Unsupported	C14-024#13-03	<b>N/A</b>	<b>N/A</b>
	SubnAdminGet(ServiceRecord)	C15-0.1.012#15	<b>Pass</b>	<b>Pass</b>
	SubnAdminGet(PathRecord)	C15-0.1.012#17.01	<b>Pass</b>	<b>Pass</b>
	SubnAdminGet(PathRecord) - Part 1	C15-0.1-012#17.02 - Part 1	<b>Pass</b>	<b>Pass</b>
	SubnAdminGet(PathRecord) - Part 2	C15-0.1-012#17.02 - Part 2	<b>Pass</b>	<b>Pass</b>
	SubnAdminGet(PathRecord) - Part 3	C15-0.1-012#17.02 - Part 3	<b>Pass</b>	<b>Pass</b>
	SM-SA Validation	SM-SA Validation	<b>Pass</b>	<b>Pass</b>

<h1 style="text-align: center;">NetApp</h1> <h2 style="text-align: center;">iSER Target</h2>		Model	E5700	
		Date	5/10/2021	
		Firmware Version	08.70.00.03	
		Overall Results	Pass	
Test Class	Name	Number	Results	
Management	ResponseTimeValue	C13-013	Pass	
	ResponseTimeValue - Single Packet	C13-014_01	Pass	
Subnet Management	No M_Key Checking	C14-015	Pass	
	M_Key Checking - SubnGet	C14-016_Get	Pass	
	M_Key Checking - SubnSet	C-14-016_Set	Pass	
	M_Key Lease Period Timer - Part 1	C-14-017	Pass	
	M_Key Lease Period Timer - Part 2		Pass	
	M_Key Lease Period Timer - Part 3		Pass	
	M_Key Lease Period Timer - Part 4		Pass	
	M_Key Lease Period Timer - Part 5		Pass	
	M_Key Violation Counter	C14-018	Pass	
	M_Key Components in NVRAM	C14-023	Pass	
	Node Description	C14-024#02	Pass	
	NodeInfo	C14-024#03	Pass	
	GUIDInfo	C14-024#05	Pass	
	PortInfo xCA - Part 1	C14-024#06_CA_01	Pass	
	PortInfo xCA - Part 2	C14-024#06_CA_02	Pass	
	PortInfo xCA - Part 3	C14-024#06_CA_03	Pass	
	PortInfo xCA - Part 4	C14-024#06_CA_04	N/A	
	PortInfo xCA - Part 5	C14-024#06_CA_05	N/A	
	PortInfo xCA - Part 6	C14-024#06_CA_06	Pass	
	PortInfo LocalPortNum	C14_024_06_LocalPortNum	Pass	
	P_Key - Part 1	C14-024#07_01	Pass	
	SLToVL Mapping - Part 1	C14-024#08_01	Pass	
	SLToVL Mapping - Part 2	C14-024#08_02	N/A	
	VLArbitration - CA	C14-024#09_xCA	Pass	
	LedInfo	C14-024#15	Pass	
	Subnet Manager	SMInfo - Supported	C14-024#13-01	N/A
		SMInfo - Unsupported	C14-024#13-03	Pass
	Subnet Administration	SubnAdminGet(ServiceRecord)	C15-0.1.012#15	N/A
SubnAdminGet(PathRecord)		C15-0.1.012#17.01	N/A	
SubnAdminGet(PathRecord) - Part 1		C15-0.1-012#17.02 - Part 1	N/A	
SubnAdminGet(PathRecord) - Part 2		C15-0.1-012#17.02 - Part 2	N/A	
SubnAdminGet(PathRecord) - Part 3		C15-0.1-012#17.02 - Part 3	N/A	
	SM-SA Validation	SM-SA Validation	N/A	



# IBTA Integrators' List

## May 2021 EDR Compliant Cables



Company Info		Cable Information					Integrators' List	Qualification
Company	Part Number	Width	Len (m)	AWG	Equalization	Type	EDR	Tested at
CONNPRO,Ind.	RIEF4TF4T20001	4x	2	30	Copper - Unequalized	QSFP28	Yes	PF38
CONNPRO,Ind.	RIHF7TF7T15001	4x	1.5	30	Copper - Unequalized	QSFP56	Yes	PF38
CONNPRO,Ind.	RIHF7TF7T20003	4x	2	26	Copper - Unequalized	QSFP56	Yes	PF38
CONNPRO,Ind.	RIHF8TF7210001	8x	1	30	Copper - Unequalized	QSFP-DD	Yes	PF38
CONNPRO,Ind.	RIHF8TF8T15001	8x	1.5	30	Copper - Unequalized	QSFP-DD	Yes	PF38
CONNPRO,Ind.	RIHF8TF7215001	8x	1.5	30	Copper - Unequalized	QSFP-DD	Yes	PF38
CONNPRO,Ind.	RIHF8TF8T20001	8x	2	30	Copper - Unequalized	QSFP-DD	Yes	PF38
CONNPRO,Ind.	AIEAF7F7L30TXX	4x	30	N/A	Fiber - Active	QSFP28	Yes	PF38
CONNPRO,Ind.	AIECF7F7L10HXX	4x	100	N/A	Fiber - Active	QSFP28	Yes	PF38
II-VI	FCBR450QB1C03	4x	3	N/A	Fiber - Active	QSFP56	Yes	PF38
II-VI	FCBR450QB1C03	4x	3	N/A	Fiber - Active	QSFP56	Yes	PF38
Nvidia	MCP1600-E00AE30	4x	0.5	30	Copper - Unequalized	QSFP28	Yes	PF38
Nvidia	MCP1600-E001E30	4x	1	30	Copper - Unequalized	QSFP28	Yes	PF38
Nvidia	MCP1600-E01AE30	4x	1.5	30	Copper - Unequalized	QSFP28	Yes	PF38
Nvidia	MCP1600-E002E30	4x	2	30	Copper - Unequalized	QSFP28	Yes	PF38
Nvidia	MCP1600-E02AE26	4x	2.5	26	Copper - Unequalized	QSFP28	Yes	PF38
Nvidia	MCP1600-E003E26	4x	3	26	Copper - Unequalized	QSFP28	Yes	PF38
Nvidia	MCP1600-E004E26	4x	4	26	Copper - Unequalized	QSFP28	Yes	PF38
Nvidia	MCP1650-H00AE30	4x	0.5	30	Copper - Unequalized	QSFP56	Yes	PF38
Nvidia	MCP1650-H001E30	4x	1	30	Copper - Unequalized	QSFP56	Yes	PF38
Nvidia	MCP1650-H02AE26	4x	2.5	26	Copper - Unequalized	QSFP56	Yes	PF38
Nvidia	MCP1650-H003E26	4x	3	26	Copper - Unequalized	QSFP56	Yes	PF38
Nvidia	MFA1A00-E003	4x	3	N/A	Fiber - Active	QSFP28	Yes	PF38
Nvidia	MFA1A00-E030	4x	30	N/A	Fiber - Active	QSFP28	Yes	PF38
Nvidia	MFA1A00-E050	4x	50	N/A	Fiber - Active	QSFP28	Yes	PF38
Nvidia	MFA1A00-E100	4x	100	N/A	Fiber - Active	QSFP28	Yes	PF38
Nvidia	MFS1S00-H003E	4x	3	N/A	Fiber - Active	QSFP56	Yes	PF38
Nvidia	MFS1S00-H050E	4x	50	N/A	Fiber - Active	QSFP56	Yes	PF38
Nvidia	MFS1S00-H100E	4x	100	N/A	Fiber - Active	QSFP56	Yes	PF38
Voalex	O1O56V26VP300	8x	3	26	Copper - Unequalized	QSFP	Yes	PF38
Voalex	DQ50BSA10BS	8x	1	30	Copper - Unequalized	QSFP-DD	Yes	PF38
Voalex	DQ58BSA20BS	8x	2	28	Copper - Unequalized	QSFP-DD	Yes	PF38
Voalex	DQ58BDA25BS	8x	2.5	26	Copper - Unequalized	QSFP-DD	Yes	PF38
Voalex	DQ58BDA30BS	8x	3	26	Copper - Unequalized	QSFP-DD	Yes	PF38



# IBTA Integrators' List

## May 2021 HDR Compliant Cables



Company Info		Cable Information					Integrators' List
Company	Part Number	Width	Len (m)	AWG	Equalization	Type	HDR
CONNPRO,Ind.	RIHF7TF7T15001	4x	1.5	30	Copper - Unequalized	QSFP56	Yes
CONNPRO,Ind.	RIHF7TF7T20003	4x	2	26	Copper - Unequalized	QSFP56	Yes
CONNPRO,Ind.	RIHF8TF7210001	8x	1	30	Copper - Unequalized	QSFP-DD	Yes
CONNPRO,Ind.	RIHF8TF8T15001	8x	1.5	30	Copper - Unequalized	QSFP-DD	Yes
CONNPRO,Ind.	RIHF8TF7215001	8x	1.5	30	Copper - Unequalized	QSFP-DD	Yes
II-VI	FCBR450QB1C03	4x	3	N/A	Fiber - Active	QSFP56	Yes
II-VI	FCBR450QB1C03	4x	3	N/A	Fiber - Active	QSFP56	Yes
Nvidia	MCP1650-H00AE30	4x	0.5	30	Copper - Unequalized	QSFP56	Yes
Nvidia	MCP1650-H02AE26	4x	2.5	26	Copper - Unequalized	QSFP56	Yes
Nvidia	MCP1650-H003E26	4x	3	26	Copper - Unequalized	QSFP56	Yes
Nvidia	MFS1S00-H003E	4x	3	N/A	Fiber - Active	QSFP56	Yes
Nvidia	MFS1S00-H050E	4x	50	N/A	Fiber - Active	QSFP56	Yes
Nvidia	MFS1S00-H100E	4x	100	N/A	Fiber - Active	QSFP56	Yes
Volex	DQ50BSA10BS	8x	1	30	Copper - Unequalized	QSFP-DD	Yes
Volex	DQ58BSA20BS	8x	2	28	Copper - Unequalized	QSFP-DD	Yes
Volex	DQ58BDA25BS	8x	2.5	26	Copper - Unequalized	QSFP-DD	Yes





# IBTA Integrators' List

## May 2021 **EDR** Interoperability List

**Hardware used to test Interoperability**

Interop Legend
MCX556A-EDAT ↔ MSB7800-ES2F ↔ <b>Cable</b> ↔ MQM8700-HS2F ↔ MBF2M516A-EEEOT
MCX653A-EDAT ↔ MSB7800-ES2F ↔ <b>Cable</b> ↔ MQM8700-HS2F ↔ MBF2M516A-EEEOT
MCX653A-EDAT ↔ MSB7800-ES2F ↔ <b>Cable</b> ↔ MBF2M516A-EEEOT
MCX556A-EDAT ↔ <b>Cable</b> ↔ MQM8700-HS2F ↔ MBF2M516A-EEEOT
MCX556A-EDAT ↔ MSB7800-ES2F ↔ <b>Cable</b> ↔ MBF2M516A-EEEOT

Conditions for passing Interop	
<b>Link Width</b>	Link width is @ expected width - i.e. 1x,4x, etc
<b>Link Speed</b>	Link speed is @ expected speed - i.e. FDR
<b>Link Recovery</b>	There must be no errors during the MPI Run
<b>Port Receive Errors</b>	There must be no errors during the MPI Run
<b>Symbol Errors</b>	There must be no errors during the MPI Run
<b>Port xmit Discard</b>	There must be no discards during the MPI Run
<b>MPI Test</b>	The MPI test must run to completion without error

Manufacturer	Description of Hardware	Model	Type	FW	SW	Speed	Status
NVIDIA	BlueField®-2 E-Series DPU 100GbE/EDR VPI Dual-Port QSFP56, PCIe Gen4 x16	MBF2M516A-EENOT	HCA	12.27.1016	MLNX_OFED_LINUX 5.3-1.0.0.1	<b>EDR</b>	<b>Compliant</b>
NVIDIA	ConnectX®-5 Ex VPI adapter card, EDR IB (100Gb/s) and 100GbE, dual-port QSFP28	MCX556A-EDAT	HCA	16.27.2008	MLNX_OFED_LINUX 5.3-1.0.0.1	<b>EDR</b>	<b>Compliant</b>
NVIDIA	ConnectX®-6 VPI adapter card, HDR IB (200Gb/s) and 200GbE, dual-port QSFP56, Socket Direct 2x PCIe3.0 x16	MCX654106A-HCAT <b>AKA</b> MCX653A-EDAT	HCA	20.27.1016	MLNX_OFED_LINUX 5.3-1.0.0.1	<b>HDR</b>	<b>Compliant</b>
NVIDIA	Switch-IB 2 based EDR InfiniBand 1U Switch, 36 QSFP28 ports, x86 dual core	MSB7800-ES2F	Switch	15.2007.0300	3.9.2400	<b>EDR</b>	<b>Compliant</b>
NVIDIA	Mellanox® Quantum(TM) HDR InfiniBand Switch, 40 QSFP56 ports, 2 Power Supplies (AC), x86 dual core	MQM8700-HS2F	Switch	27.2007.0300	3.9.2400	<b>HDR</b>	<b>Compliant</b>

**Software Used to Test Interoperability**

Software	Versions
Operating System	<a href="#">Cent OS 8.3.2011</a>
Mellanox OFED	<a href="#">MLNX OFED 5.3-1.0.0.1</a>
Open MPI	<a href="#">Open MPI 4.1.1</a>
Open MPI Documentation	<a href="https://www.open-mpi.org/doc/">https://www.open-mpi.org/doc/</a>
Benchmark	<a href="#">Intel MPI Benchmarks</a>
Test Plan	<a href="#">Software Forge IBTA MOI Suite</a>
Duration	2-5 Minutes

Open MPI Intel Benchmark Tests	
PingPong	Gather
PingPing	Gatherv
Sendrecv	Scatter
Exchange	Scatterv
Allreduce	Alltoall
Reduce	Alltoallv
Reduce_scatter	Bcast
Allgather	Barrier
Allgatherv	



# IBTA Integrators' List

## May 2021 EDR Interoperability List



Company Info		Cable Information					Interop-01	Interop-02	Interop-03	Interop-04	Interop-05
Company	Part Number	Width	Len (m)	AWG	Equalization	Connector Type	MSB7800-SW MQM8700-SW	MSB7800-SW MQM8700-SW	MSB7800-SW MBF2M516A	MCX556A MSB7800-SW	MSB7800 MBF2M516A
CONNPRO,Ind.	RIEF4TF4T20001	4x	2	30	Copper - Unequalized	QSFP28	Yes	No	Yes	Yes	Yes
CONNPRO,Ind.	RIHF7TF7T15001	4x	1.5	30	Copper - Unequalized	QSFP56	Yes	No	Yes	Yes	Yes
CONNPRO,Ind.	RIHF7TF7T20003	4x	2	26	Copper - Unequalized	QSFP56	Yes	No	Yes	Yes	Yes
CONNPRO,Ind.	RIHF8TF7210001	8x	1	30	Copper - Unequalized	QSFP-DD	N/A	N/A	N/A	N/A	N/A
CONNPRO,Ind.	RIHF8TF8T15001	8x	1.5	30	Copper - Unequalized	QSFP-DD	N/A	N/A	N/A	N/A	N/A
CONNPRO,Ind.	RIHF8TF7215001	8x	1.5	30	Copper - Unequalized	QSFP-DD	N/A	N/A	N/A	N/A	N/A
CONNPRO,Ind.	RIHF8TF8T20001	8x	2	30	Copper - Unequalized	QSFP-DD	N/A	N/A	N/A	N/A	N/A
CONNPRO,Ind.	AIEAF7F7L30TXX	4x	30	N/A	Fiber - Active	QSFP28	Yes	No	Yes	Yes	Yes
CONNPRO,Ind.	AIECF7F7L10HXX	4x	100	N/A	Fiber - Active	QSFP28	Yes	No	Yes	Yes	Yes
II-VI	FCBR450QB1C03	4x	3	N/A	Fiber - Active	QSFP56	No	No	No	No	No
II-VI	FCBR450QB1C03	4x	3	N/A	Fiber - Active	QSFP56	No	No	No	No	No
Nvidia	MCP1600-E00AE30	4x	0.5	30	Copper - Unequalized	QSFP28	Yes	Yes	Yes	Yes	Yes
Nvidia	MCP1600-E001E30	4x	1	30	Copper - Unequalized	QSFP28	Yes	Yes	Yes	Yes	Yes
Nvidia	MCP1600-E01AE30	4x	1.5	30	Copper - Unequalized	QSFP28	Yes	Yes	Yes	Yes	Yes
Nvidia	MCP1600-E002E30	4x	2	30	Copper - Unequalized	QSFP28	Yes	Yes	Yes	Yes	Yes
Nvidia	MCP1600-E02AE26	4x	2.5	26	Copper - Unequalized	QSFP28	Yes	Yes	Yes	Yes	Yes
Nvidia	MCP1600-E003E26	4x	3	26	Copper - Unequalized	QSFP28	Yes	Yes	Yes	Yes	Yes
Nvidia	MCP1600-E004E26	4x	4	26	Copper - Unequalized	QSFP28	Yes	Yes	Yes	Yes	Yes
Nvidia	MCP1650-H00AE30	4x	0.5	30	Copper - Unequalized	QSFP56	Yes	Yes	Yes	Yes	Yes
Nvidia	MCP1650-H001E30	4x	1	30	Copper - Unequalized	QSFP56	Yes	Yes	Yes	Yes	Yes
Nvidia	MCP1650-H02AE26	4x	2.5	26	Copper - Unequalized	QSFP56	Yes	Yes	Yes	Yes	Yes
Nvidia	MCP1650-H003E26	4x	3	26	Copper - Unequalized	QSFP56	Yes	Yes	Yes	Yes	Yes
Nvidia	MFA1A00-E003	4x	3	N/A	Fiber - Active	QSFP28	Yes	Yes	Yes	Yes	Yes
Nvidia	MFA1A00-E030	4x	30	N/A	Fiber - Active	QSFP28	Yes	Yes	Yes	Yes	Yes
Nvidia	MFA1A00-E050	4x	50	N/A	Fiber - Active	QSFP28	Yes	Yes	Yes	Yes	Yes
Nvidia	MFA1A00-E100	4x	100	N/A	Fiber - Active	QSFP28	Yes	Yes	Yes	Yes	Yes
Nvidia	MFS1S00-H003E	4x	3	N/A	Fiber - Active	QSFP56	N/A	N/A	N/A	N/A	N/A
Nvidia	MFS1S00-H050E	4x	50	N/A	Fiber - Active	QSFP56	N/A	N/A	N/A	N/A	N/A
Nvidia	MFS1S00-H100E	4x	100	N/A	Fiber - Active	QSFP56	N/A	N/A	N/A	N/A	N/A
Volex	O1O56V26VP300	8x	3	26	Copper - Unequalized	QSFP	N/A	N/A	N/A	N/A	N/A
Volex	DQ50BSA10BS	8x	1	30	Copper - Unequalized	QSFP-DD	N/A	N/A	N/A	N/A	N/A
Volex	DQ58BSA20BS	8x	2	28	Copper - Unequalized	QSFP-DD	N/A	N/A	N/A	N/A	N/A
Volex	DQ58BDA25BS	8x	2.5	26	Copper - Unequalized	QSFP-DD	N/A	N/A	N/A	N/A	N/A
Volex	DQ58BDA30BS	8x	3	26	Copper - Unequalized	QSFP-DD	N/A	N/A	N/A	N/A	N/A
					<b>Legend</b>	<b>Scenario</b>	<b>HCA #1</b>	<b>Switch #1</b>	<b>Link Under Test</b>	<b>Switch #2</b>	<b>HCA #2</b>
					EDR	Interop-01	MCX556A-EDAT	MSB7800-ES2F	See List Above	MQM8700-HS2F	MBF2M516A-EEEOT
					HDR	Interop-02	MCX653A-EDAT	MSB7800-ES2F	See List Above	MQM8700-HS2F	MBF2M516A-EEEOT
						Interop-03	MCX653A-EDAT	MSB7800-ES2F	See List Above	N/A	MBF2M516A-EEEOT
						Interop-04	MCX556A-EDAT	N/A	See List Above	MQM8700-HS2F	MBF2M516A-EEEOT
						Interop-05	MCX556A-EDAT	MSB7800-ES2F	See List Above	N/A	MBF2M516A-EEEOT



# IBTA Integrators' List

## May 2021 HDR Interoperability List



### Hardware used to test Interoperability

Interop Legend
MCX653A-HCAT ↔ Cable ↔ MQM8700-HS2F ↔ MCX653A-HCAT

Conditions for passing Interop	
<b>Link Width</b>	Link width is @ expected width - i.e. 1x,4x, etc
<b>Link Speed</b>	Link speed is @ expected speed - i.e. FDR
<b>Link Recovery</b>	There must be no errors during the MPI Run
<b>Port Receive Errors</b>	There must be no errors during the MPI Run
<b>Symbol Errors</b>	There must be no errors during the MPI Run
<b>Port xmit Discard</b>	There must be no discards during the MPI Run
<b>MPI Test</b>	The MPI test must run to completion without error

Manufacturer	Description of Hardware	Model	Type	HW	FW	SW	Speed	Status
NVIDIA	ConnectX®-6 VPI adapter card, HDR IB (200Gb/s) and 200GbE, dual-port QSFP56	MCX653A-HCAT	HCA	A5	20.27.1016	5.0-2.1.8.0	HDR	Compliant
NVIDIA	NVIDIA® Quantum(TM) HDR InfiniBand Switch, 40 QSFP56 ports	MQM8700-HS2F	Switch	A6	27.2007.0300	3.9.0300	HDR	Compliant

### Software Used to Test Interoperability

Software	Versions
Operating System	<a href="#">Cent OS 8.3.2011</a>
Mellanox OFED	<a href="#">MLNX OFED 5.3-1.0.0.1</a>
Open MPI	<a href="#">Open MPI 4.1.1</a>
Open MPI Documentation	<a href="https://www.open-mpi.org/doc/">https://www.open-mpi.org/doc/</a>
Benchmark	<a href="#">Intel MPI Benchmarks</a>
Test Plan	<a href="#">Software Forge IBTA MOI Suite</a>
Duration	2-5 Minutes

Open MPI Intel Benchmark Tests	
PingPong	Gather
PingPing	Gatherv
Sendrecv	Scatter
Exchange	Scatterv
Allreduce	Alltoall
Reduce	Alltoallv
Reduce_scatter	Bcast
Allgather	Barrier
Allgatherv	



# IBTA Integrators' List

## May 2021 HDR Interoperability List



Company Info		Cable Information					HDR Interop
Company	Part Number	Width	Len (m)	AWG	Equalization	Connector Type	MQM8700-SW MCX653A-HCA
CONNPRO,Ind.	RIHF7TF7T15001	4x	1.5	30	Copper - Unequalized	QSFP56	Yes
CONNPRO,Ind.	RIHF7TF7T20003	4x	2	26	Copper - Unequalized	QSFP56	Yes
CONNPRO,Ind.	RIHF8TF7210001	8x	1	30	Copper - Unequalized	QSFP-DD	N/A
CONNPRO,Ind.	RIHF8TF8T15001	8x	1.5	30	Copper - Unequalized	QSFP-DD	N/A
CONNPRO,Ind.	RIHF8TF7215001	8x	1.5	30	Copper - Unequalized	QSFP-DD	N/A
II-VI	FCBR450QB1C03	4x	3	N/A	Fiber - Active	QSFP56	Yes
II-VI	FCBR450QB1C03	4x	3	N/A	Fiber - Active	QSFP56	Yes
Nvidia	MCP1650-H00AE30	4x	0.5	30	Copper - Unequalized	QSFP56	Yes
Nvidia	MCP1650-H001E30	4x	1	30	Copper - Unequalized	QSFP56	Yes
Nvidia	MCP1650-H02AE26	4x	2.5	26	Copper - Unequalized	QSFP56	Yes
Nvidia	MCP1650-H003E26	4x	3	26	Copper - Unequalized	QSFP56	Yes
Nvidia	MFS1S00-H003E	4x	3	N/A	Fiber - Active	QSFP56	Yes
Nvidia	MFS1S00-H050E	4x	50	N/A	Fiber - Active	QSFP56	Yes
Nvidia	MFS1S00-H100E	4x	100	N/A	Fiber - Active	QSFP56	Yes
Volex	DQ50BSA10BS	8x	1	30	Copper - Unequalized	QSFP-DD	N/A
Volex	DQ58BSA20BS	8x	2	28	Copper - Unequalized	QSFP-DD	N/A
Volex	DQ58BDA25BS	8x	2.5	26	Copper - Unequalized	QSFP-DD	N/A

---

# InfiniBand Trade Association

## Plugfest 38 Test Equipment Providers

The **IBTA** wishes to thank **Anritsu, Keysight, Software Forge, Ace Unitech** and **Wilder Technologies** for providing the following test equipment and software for the IBTA Plugfests. All this equipment is provided free of charge for the benefit of the InfiniBand community and the IBTA Plugfests would not be possible without this equipment.



## Anritsu - Signal Quality Analyzer MP1900A

The MP1900A Signal Quality Analyzer is an expandable modular NRZ and PAM4 BERT supporting wideband bit rates from 2.4Gb/s to 128Gb/s for versatile signal integrity analysis applications. Supports IBTA and IEEE rates such as HDR (PAM4 26.56Gbaud x4), EDR (NRZ 25.78Gb/s x4). Supports all 200G/400G PAM4 and NRZ rates defined by IBTA, IEEE, OIF-CEI, Fiber Channel standards.

### MP1900A System Features:

- Pulse Pattern Generator supports output of high-quality / low jitter NRZ and PAM4 waveforms. Integrated emphasis and flexible pattern generation for PAM4 applications.
- Error Detector with high input sensitivity and integrated clock recovery. Includes signal analysis tools such as Bathtub, Jitter Decomposition, and Eye Contour. Integrated real-time PAM4 decoding for BER/SER and powerful jitter tolerance applications.
- Integrated Jitter Modulation for SJ/RJ/BUJ/SSC generation and supporting Jitter Tolerance tests.
- Integrated Noise injection to address standards-based stressed signal requirements. (CM, DM, White)

### IBTA Application:

- Supports HDR, EDR, FDR, QDR Active Cable Time Domain Testing (ATD).
- Multi-channel PPG to create victim and aggressor traffic.
- Jitter Modulation Source to inject jitter onto the victim channel to create stressed conditions.
- Multi-Channel error detection for BER analysis during stressed receiver testing.

### MP1900A Literature: (hyperlink)

[Signal Quality Analyzer-R MP1900A - 32G/64G NRZ/PAM4 Signal Integrity Test Solution](#)

[Signal Quality Analyzer-R MP1900A - PCIe/USB/Thunderbolt Test Solutions](#)



## Anritsu – MP2110A- BERTWave

The MP2110A BERTWave supports simultaneous 4 channel pattern generation and BER measurements with sampling scope eye pattern analysis for evaluating optical and electrical signals. Enhanced sampling scope measurements available with Jitter Analysis and PAM4 Analysis software.

### IBTA Application:

- Aggressor traffic for HDR, EDR, FDR, QDR ATD Testing
- Simultaneous 4 channel BER measurements for EDR, FDR, QDR ATD Testing
- 40GHz BW Sampling Scope with Jitter Analysis and Precision Trigger
- Eye Mask functions for DUT measurements
- Jitter Decomposition (TJ, DJ, J2, J9, DDWPS) for DUT measurements

### MP2110A - BERTWave Literature:



[View Product Brochure](#) **UPDATED**



[Video](#)

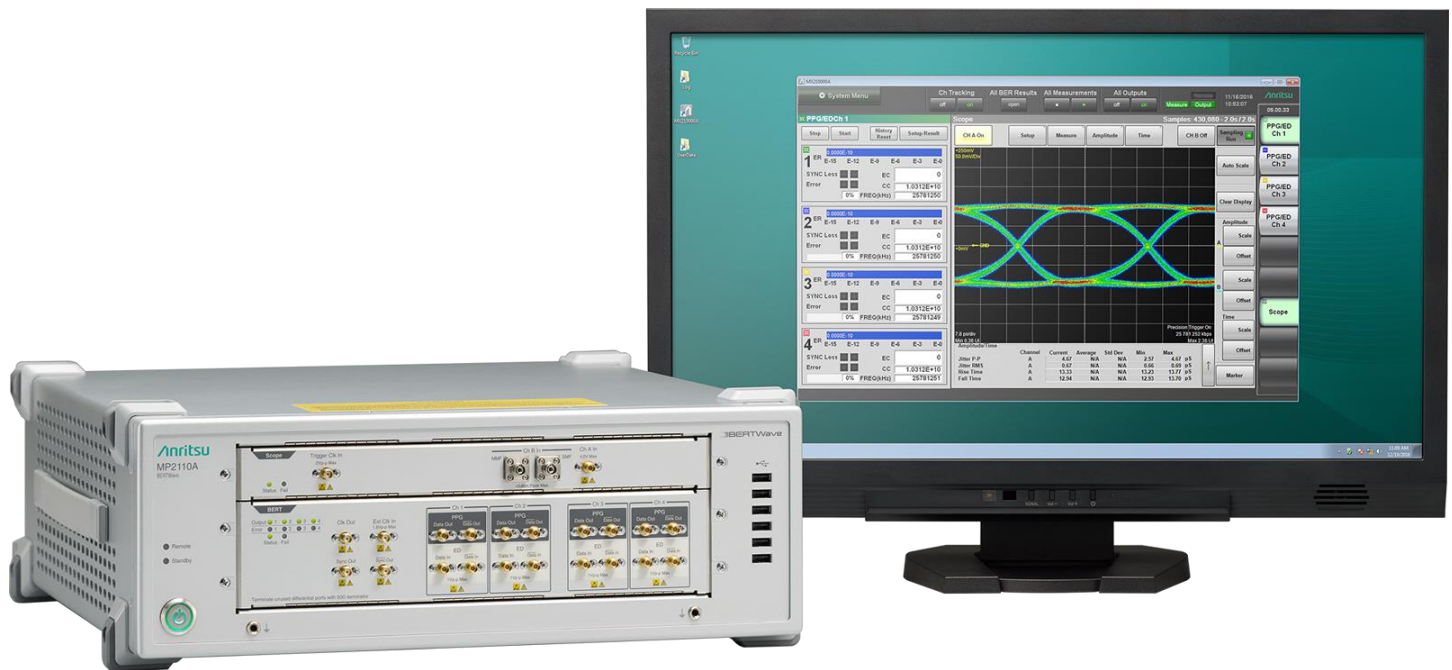

**MP2110A Front View with External Monitor**

## Anritsu – MT1000A Network Master Pro

The MT1000A is an all-in-one portable tester with expandability and operability for speeds up to 100Gb/s. The compact, battery-powered and easy-to-use Anritsu MT1000A provides everything needed to install and maintain communication networks in a rugged, field portable package. This lightweight instrument simplifies the task of collecting and interpreting data with an easy-to-use GUI and clear summaries allowing users of any skill level to operate the instrument to its full potential. The MT1000A's installed MU100011A module provides the appropriate signal interfaces for testing performed at IBTA Plugfests.

### IBTA Application:

- 4 Channel Pattern Generator provides required signal activity for DUTs measured on VNA Station.
- 4 Channel Pattern Generator can provide Aggressor traffic for EDR ATD Station.
- 4 Channel Error Detector can provide BER measurements for EDR ATD Station.
- **Wilder HCB used for interconnect between QSFP28 and SMA.**

### MT1000A Network Master Pro Literature:

1. <https://www.anritsu.com/en-us/test-measurement/products/mt1000a>
2. <https://www.anritsu.com/en-US/test-measurement/support/downloads/brochures-datasheets-and-catalogs/dwl010587>
3. <https://www.anritsu.com/en-US/test-measurement/support/downloads/brochures-datasheets-and-catalogs/dwl010570>

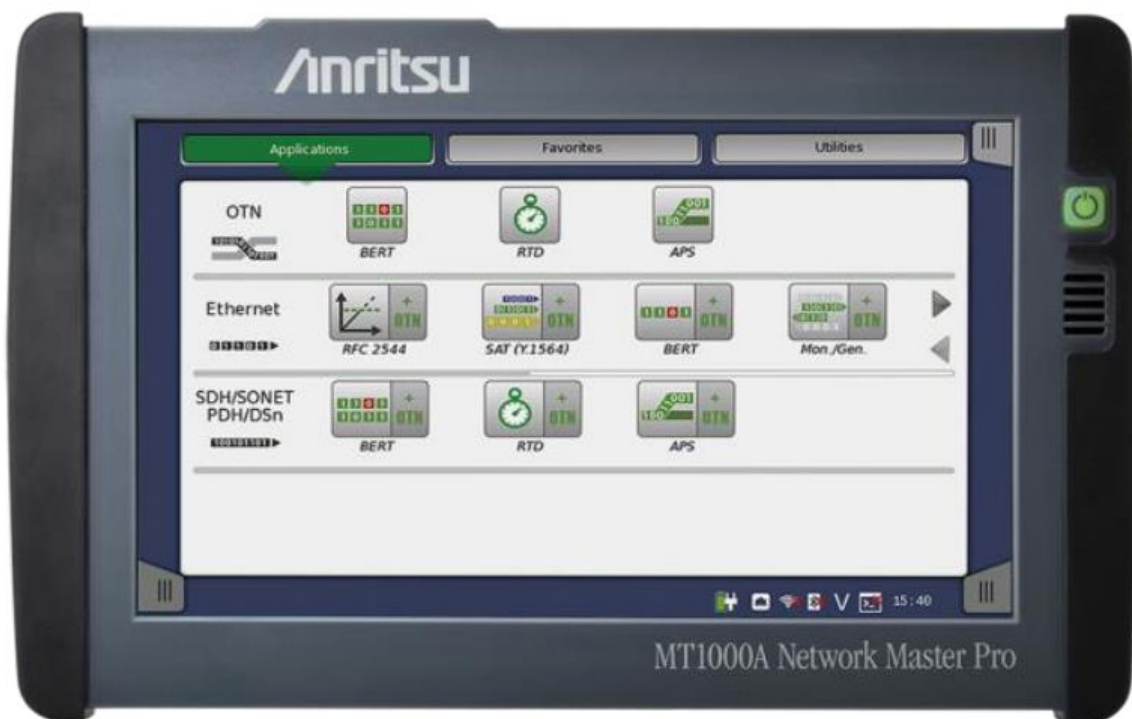

MT1000A Front View

### Anritsu – MT1040A Network Master Pro

The MT1040A is an all-in-one portable tester with expandability and operability for speeds up to 400Gb/s. The compact, battery-powered and easy-to-use Anritsu MT1040A provides everything needed to install and maintain communication networks in a rugged, field portable package. This lightweight instrument simplifies the task of collecting and interpreting data with an easy-to-use GUI and clear summaries allowing users of any skill level to operate the instrument to its full potential. The MT1040A can support multiple ports of QSFP+, QSFP28, QSFP-DD and OSFP interfaces, depending on its transport module configuration (illustrated below). MT1040A mainframe will support up to 2 transport modules listed below (MU104014A / 15A / 11A)

#### IBTA Application:

- Dual channel 100G / 200G configurations can support EDR & HDR cable testing with FEC in a single mainframe.

#### MT1040A Network Master Pro Literature:

1. <https://www.anritsu.com/en-us/test-measurement/products/mt1040a>
2. <https://dl.cdn-anritsu.com/en-en/test-measurement/files/Brochures-Datasheets-Catalogs/Brochure/mt1040a-400g-brochure-e1101.pdf>
3. <https://dl.cdn-anritsu.com/en-en/test-measurement/files/Product-Introductions/Product-Introduction/mt1040a-400g-product-intro-el4101.pdf>



MT1040A Outline

#### MU104011A 100G



#### Test interface

100G/40G/25G/10G/1G/100M/10M 2port

#### MU104014A 400G (QSFP-DD)



#### Test Interface

200/ 400G 1port (QSFP-DD)  
100G/40G/25G/10G/1G/100M/10M 2port



## Keysight - Wide-Bandwidth Equivalent-Time (Sampling) Oscilloscope (DCA-X)

The Keysight N1000A/86100D DCA-X family of oscilloscopes, together with the N1060A Precision Waveform Analyzer (aka “MegaModule”) plug-in module, has been engineered to provide precision measurements on high-speed electrical communications systems and components:

- Fast and accurate jitter/eye/analysis of NRZ and PAM4 signals
- Bandwidth: 50 GHz / 85 GHz (95 GHz typ)
- Intrinsic random jitter (RJ): 50 fs rms (typ)
- Built-in clock recovery: 150 MBd to 64 Gbd (continuous), with integrated EQ for “closed eye” analysis

The N1060A provides accurate jitter analysis, eye diagram, and waveform characterization on InfiniBand (HDR, EDR, FDR, QDR ATD Testing), Ethernet, OIF-CEI, and Fibre Channel applications to 64 Gbd.



N1000A\_DCA-X\_with\_N1060A\_module



Eye Mask, J2, J9, Time Domain

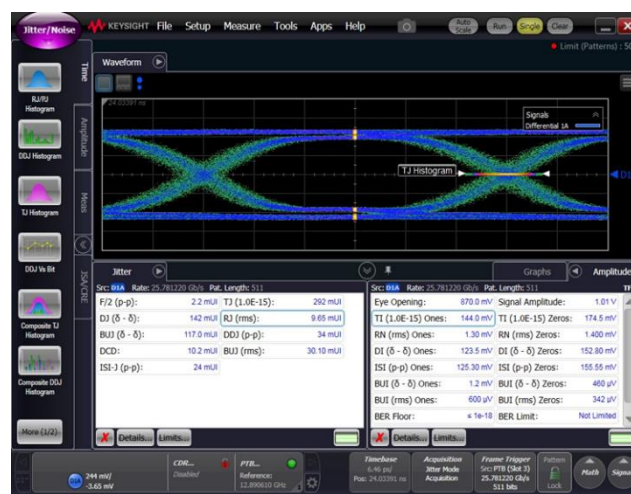

Eye Width & Height, Jitter Analysis

### Links

1. N1000A DCA-X Wide-Bandwidth Oscilloscope: [N1000A](#)
2. N1060A Precision Waveform Analyzer (“MegaModule”): [N1060A](#)
3. Software Compliance Applications for the DCA-X platform: [SW Apps](#)

**IBTA Application:** FDR/EDR/HDR HCA and Switch physical layer testing, and EDR/HDR Active Cable Time Domain testing.



## Keysight - Network Analyzers

### 1) ENA used in FDR Cables testing

- a) [E5071C](#): 20 GHz ENA Series Network Analyzer
- b) E5071C Data Sheet: <http://literature.cdn.keysight.com/litweb/pdf/5989-5479EN.pdf>

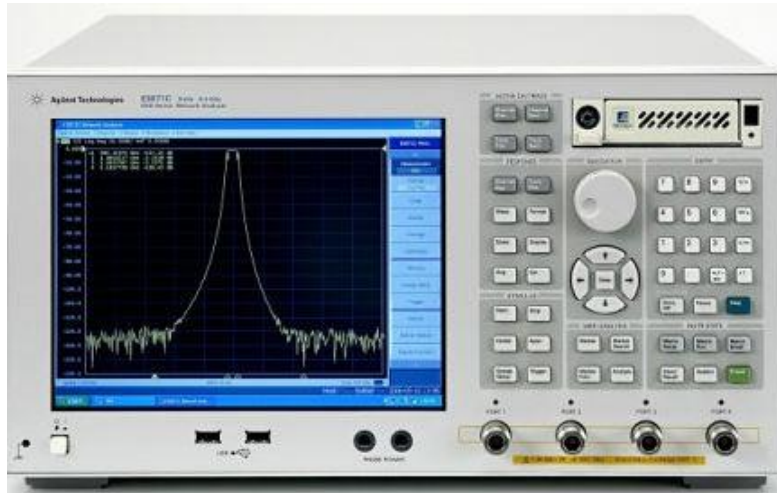

20 GHz ENA Series Network Analyzer

### 2) N5244A PNA-X Microwave Network Analyzer used in EDR Cables testing

- a) [N5244A](#): 43.5 GHz ENA Series Network Analyzer
- b) N5244A PNA-X Data Sheet: <http://literature.cdn.keysight.com/litweb/pdf/N5245-90008.pdf>

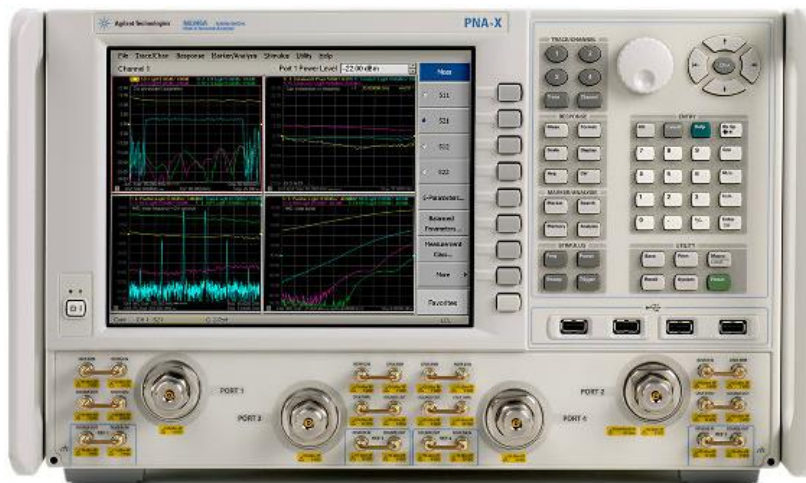

### IBTA Application:

- FDR Device Physical Layer testing: SDDxx, SCCxx and SDCxx
- FDR and EDR Cable testing. ICN, ICMCN, SDDxx, SCCxx and SDCxx

### 3) 32 Port VNA used in FDR and EDR Cable testing since PF29

- a) [M9375A](#): PXIe Vector Network Analyzer
- b) [M9019A](#): M9019A PXIe Chassis
- c) PLTS: Physical Layer Test Suite – software to process s32p files

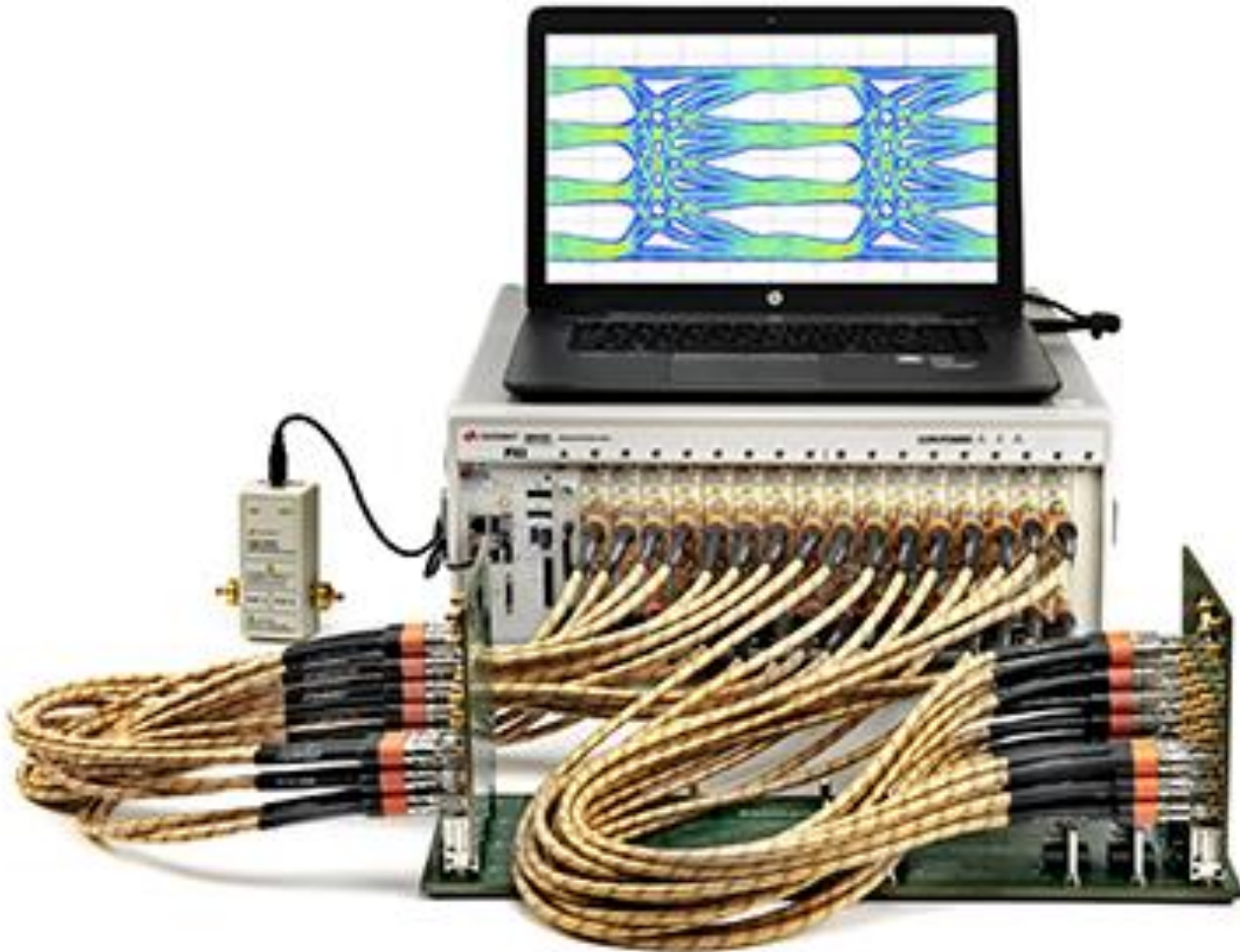

#### **IBTA Application:**

- FDR and EDR Cable testing. ICN, ICMCN, ILD, SDDxx, SCCxx and SDCxx

## Software Forge – Compliance Test Suite (CTS)

The current version of CTS provides InfiniBand Protocol Layer testing. It is based on the Compliance and Interoperability Working Group InfiniBand Test Specification ([Volume 3](#)). This tool has replaced the old Agilent TCL test suite.

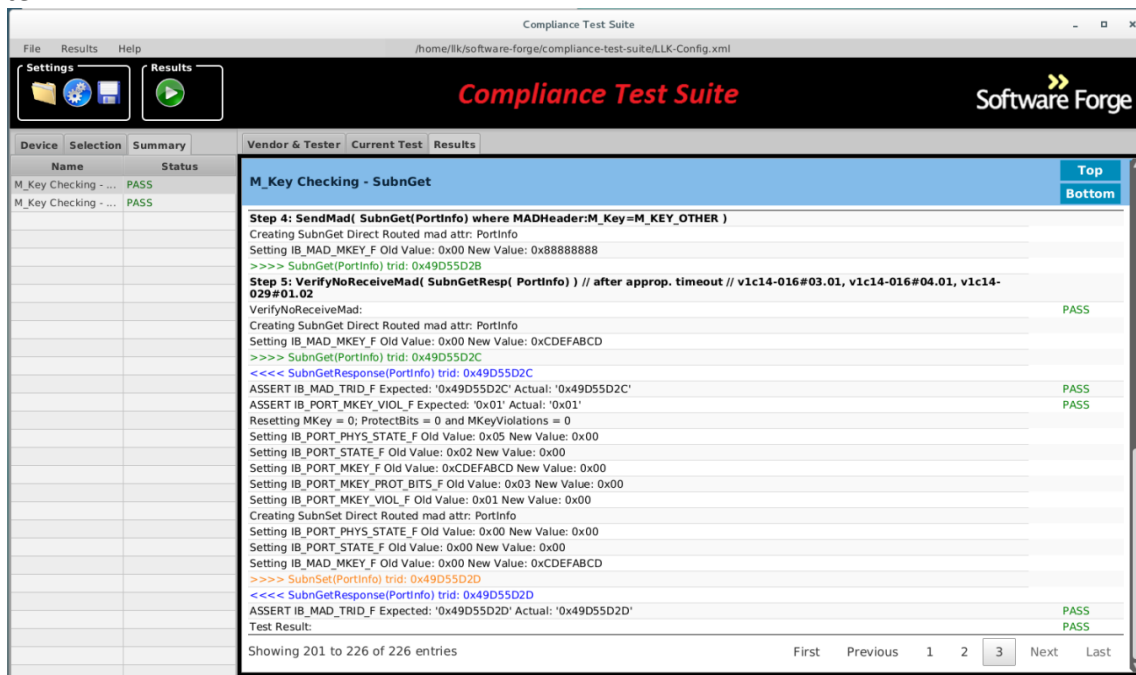

## Software Forge – EEPROM Command Center (ECC)

The EEPROM Command Center is an application which enables the user to control and monitor the status of the QSFP memory maps. The user can write to writable fields of the QSFP memory map and easily export summaries of the results.

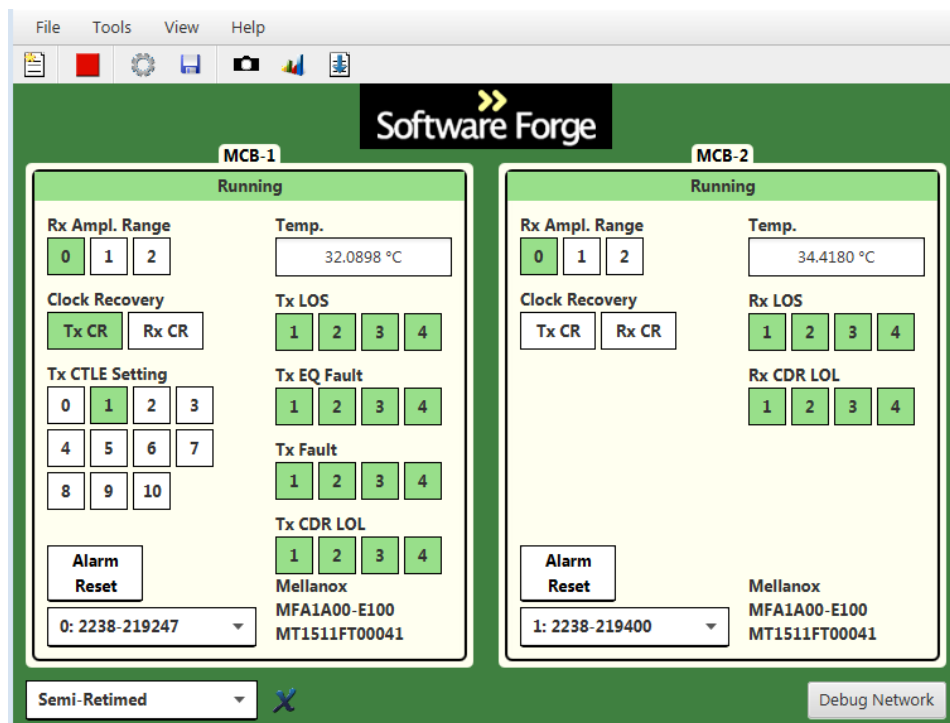

## Software Forge – Vector Network Analyzer (VNA) MATLAB Application

This Application analyzes and processes the s32p VNA data so that the results are available immediately after the data is collected. This has helped reduce the data analysis time from months to minutes.

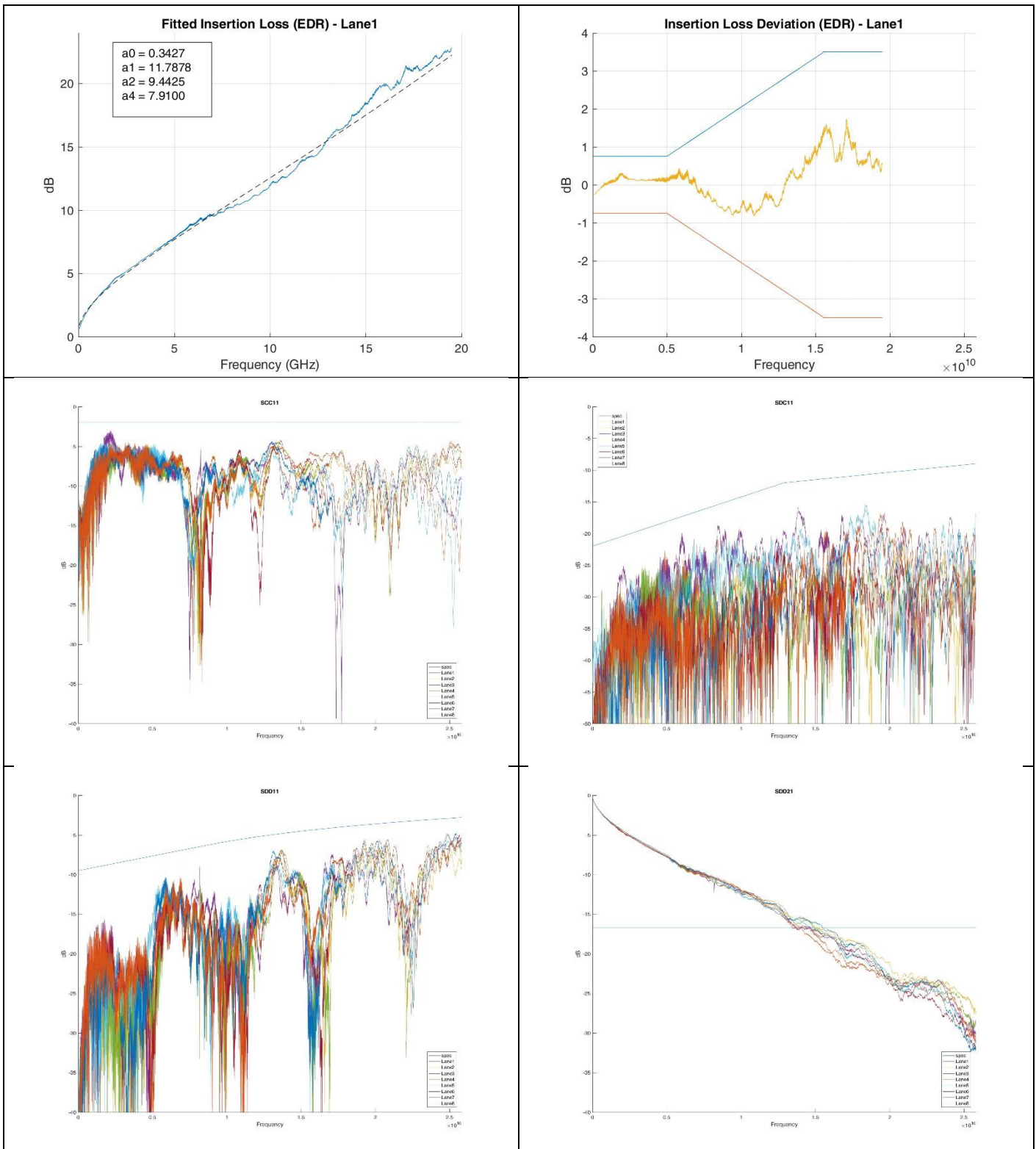

## Software Forge – High Performance Computing – Performance Monitor ([HPC-PM](#))

The High Performance Computing – Performance Monitor (HPC-PM) measures network performance of RDMA and/or TCP connections. The tool can be used for network diagnostics as well as engineering.

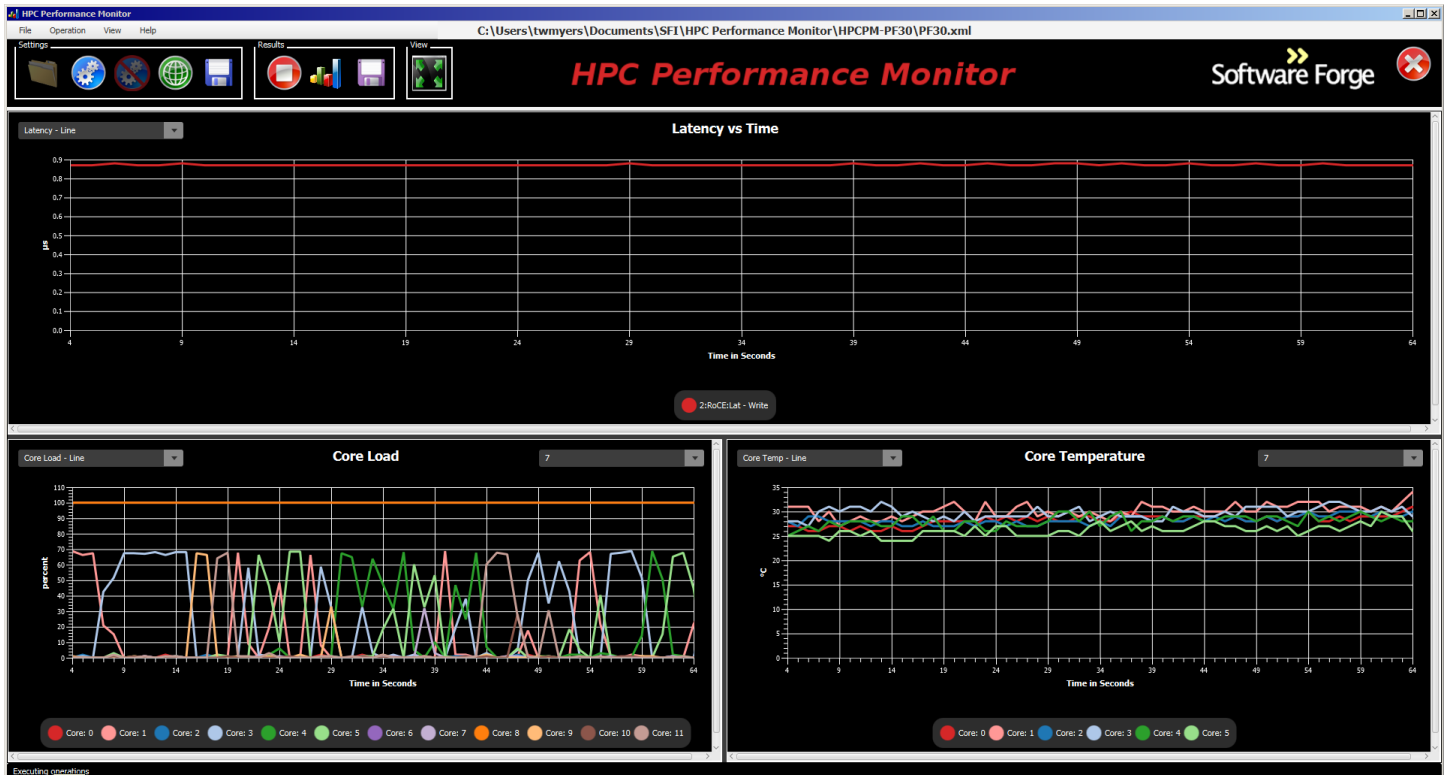



## Total Phase

### I2C/SPI Host Adapter Test fixture

The Aardvark I2C/SPI Host Adapter is a fast and powerful I2C bus and SPI bus host adapter through USB. It allows a developer to interface a Windows, Linux, or Mac OS X PC via USB to a downstream embedded system environment and transfer serial messages using the I2C and SPI protocols.



<http://www.totalphase.com/products/aardvark-i2cspi/?gclid=ClzW2sDjg8QCFWQV7Aod3RwAvA>

### EEPROM Programming Kit

Total Phase has bundled together a complete set of development tools and accessories that allow developers to erase, program, and verify serial EEPROMs.



<http://www.totalphase.com/catalog/product/view/id/24/s/eeprom-devkit/category/4/>

**IBTA Application:** Used to program EEPROM cable modules when doing ATD testing and in general for reprogramming EEPROMs as needed.

## Ace Unitech – Variable ISI Channel

### CLE-1000-S2

Designed as a variable Inter-Symbol-Interference (ISI) channel for high speed serial interface stress tests. It controls the insertion loss continuously at 0.1% step (1,000 steps) in its dynamic range for fine adjustment. The differential transmission lines are totally passive and DC coupled. The adjusted insertion loss amount is reliably repeatable and stable for secure test results. The control is done by the volume dial on the front panel and/or PC remote via USB for automated calibration. Three (3) models of different loss range are prepared to cover various data rates. 4ch versions are also available. The CLE1000 is a convenient ISI channel, applicable for various standard stress tests and compliance tests.

#### IBTA Application:

- EDR Active Cable Time Domain Testing (ATD)
- Precise adjustment of frequency-dependent input channel loss.

### CLE-1000-S2

1. <http://www.aceunitech.com/index.html>
2. [http://www.aceunitech.com/docs/support/cl1000\\_datasheet.pdf](http://www.aceunitech.com/docs/support/cl1000_datasheet.pdf)

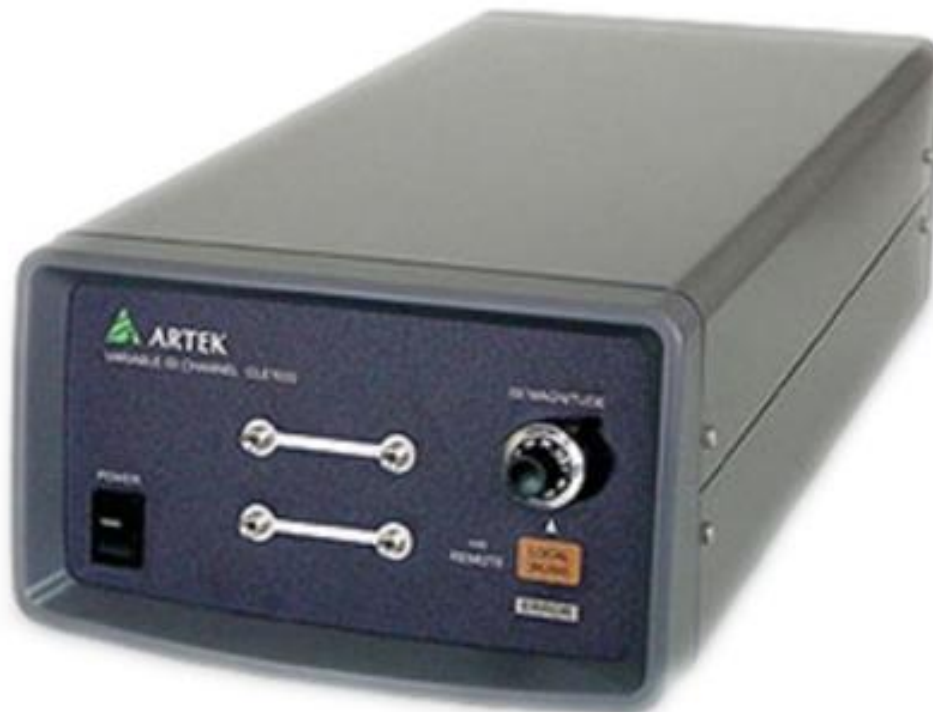

**CLE-1000-S2 Front View**

**Wilder** QSFP28 Test fixture:

<https://www.wilder-tech.com/en/products/datacomm#qsfp-28>

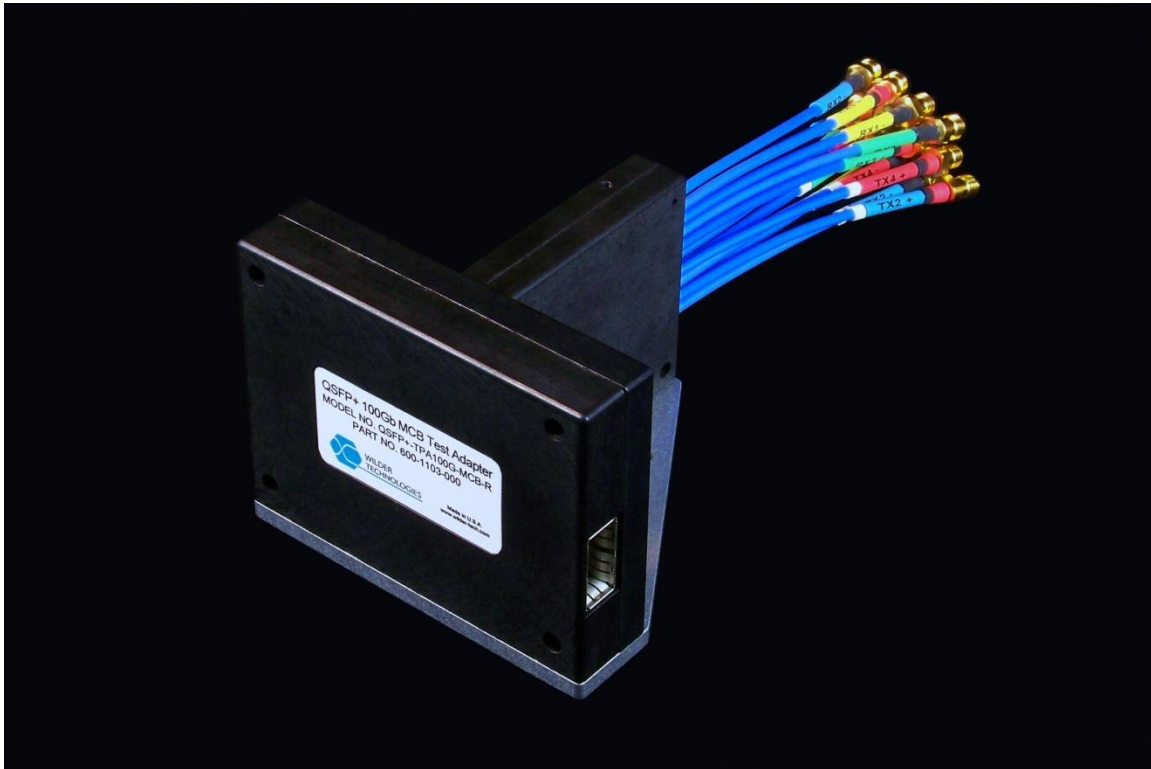

**Wilder** QSFP28 Module Compliance Board (MCB)

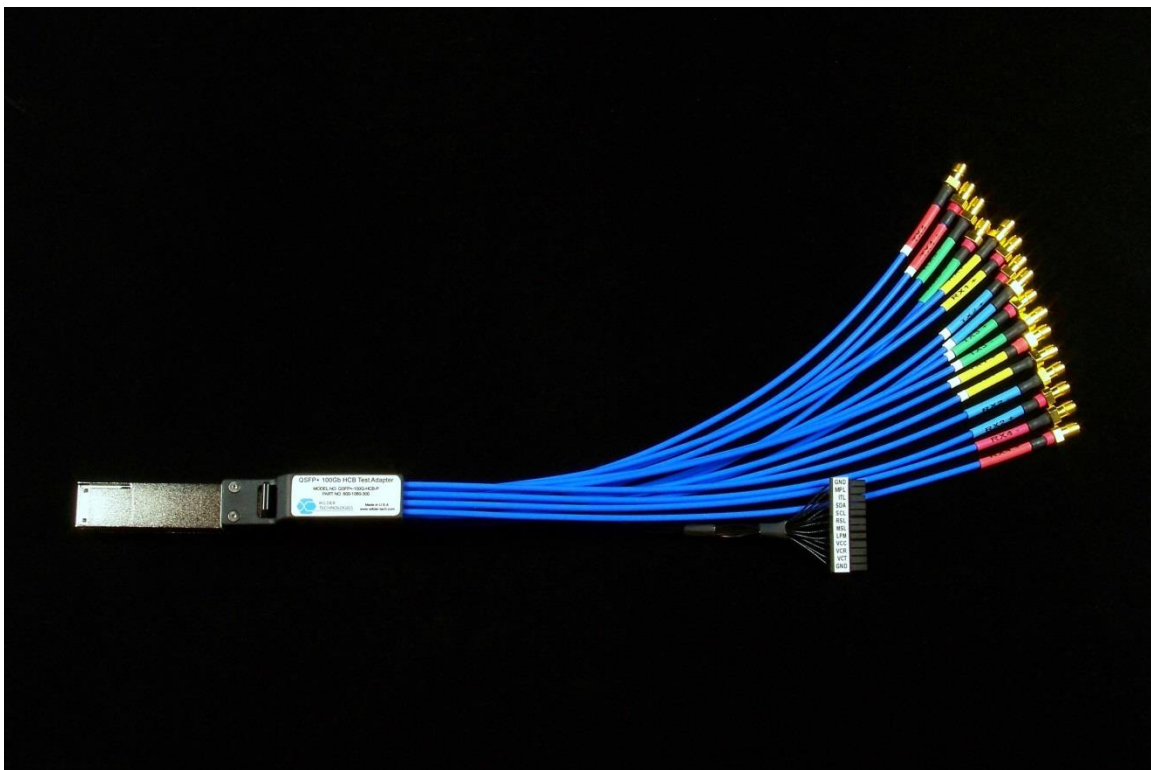

**Wilder** QSFP28 Host Compliance Board (HCB)

## Wilder QSFP28 Test fixture:

<https://www.wilder-tech.com/en/products/datacomm#qsfp-28>

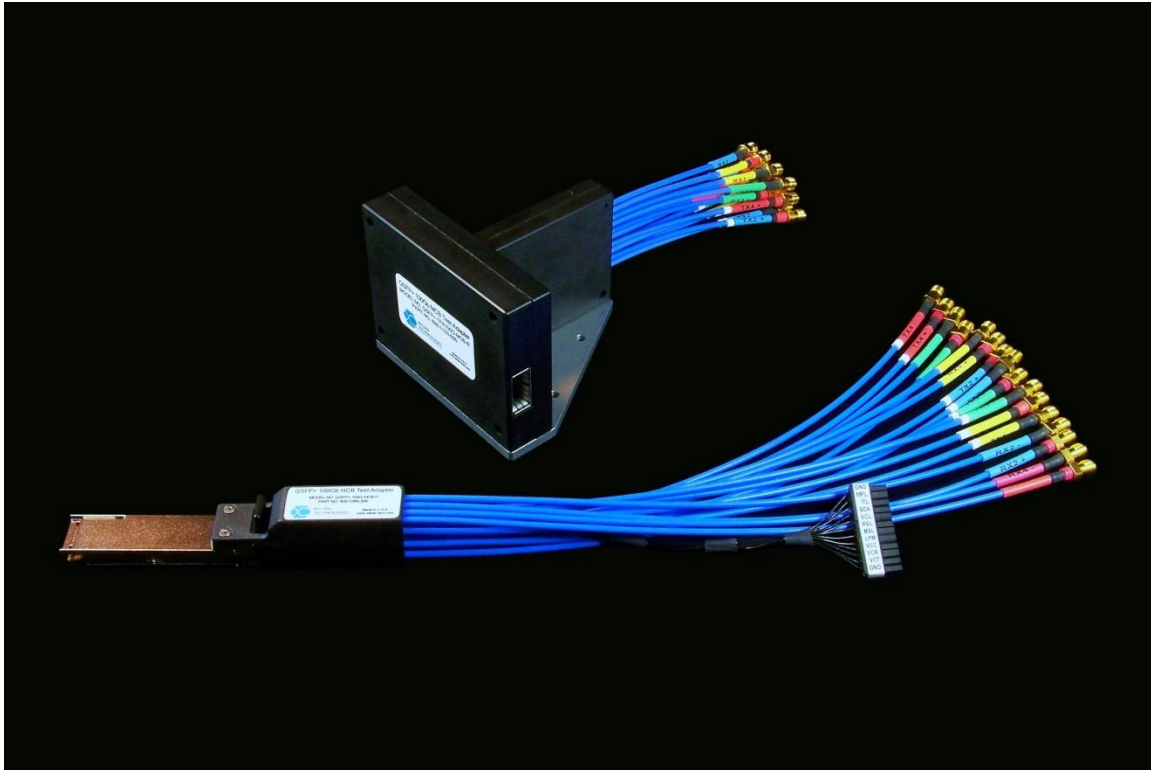

**Wilder QSFP28 Module Compliance Board (MCB) / Host Compliance Board (HCB)**

### IBTA Applications:

- Wilder HCB
  - QDR, FDR, EDR and HDR device physical layer testing
  - QDR, FDR, EDR and HDR Active Cable Time Domain testing
- Wilder MCB
  - QDR, FDR, EDR and HDR Active Cable Time Domain testing
  - QDR, FDR, EDR and HDR VNA testing

## Wilder Dual Headed HCBs for VNA MCB verification

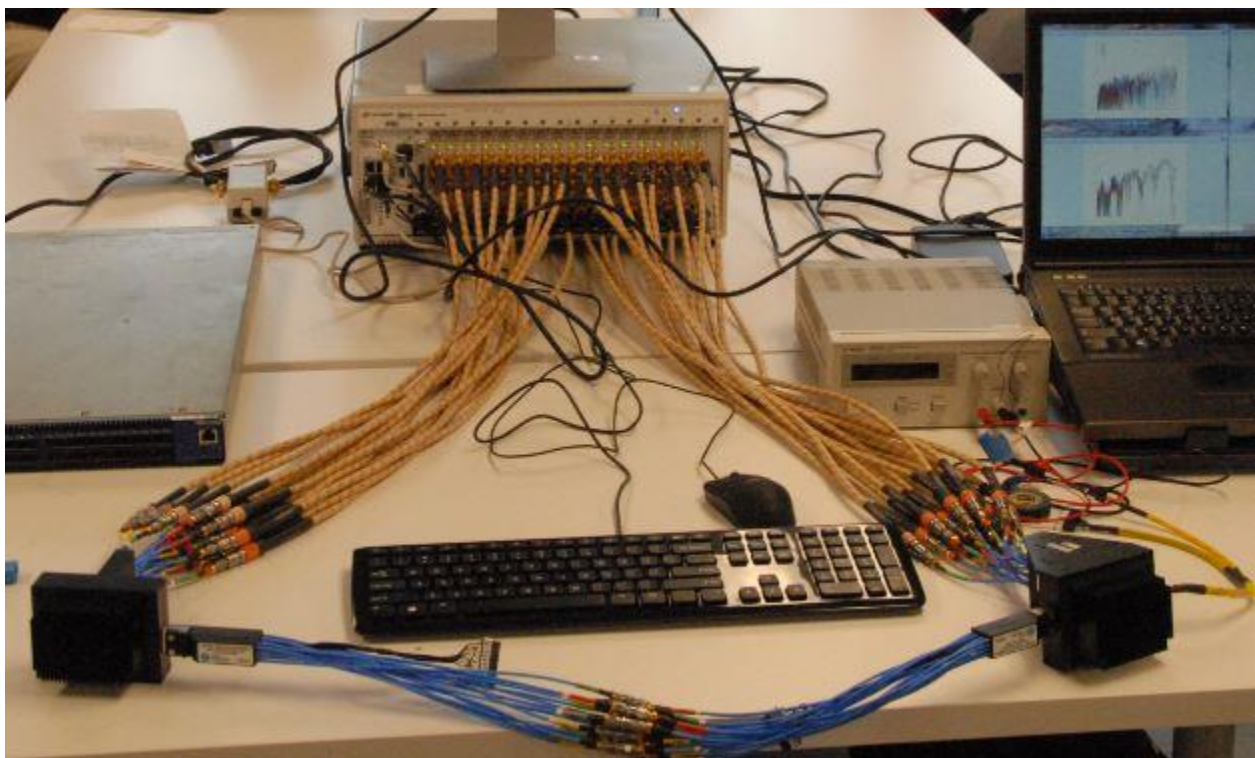
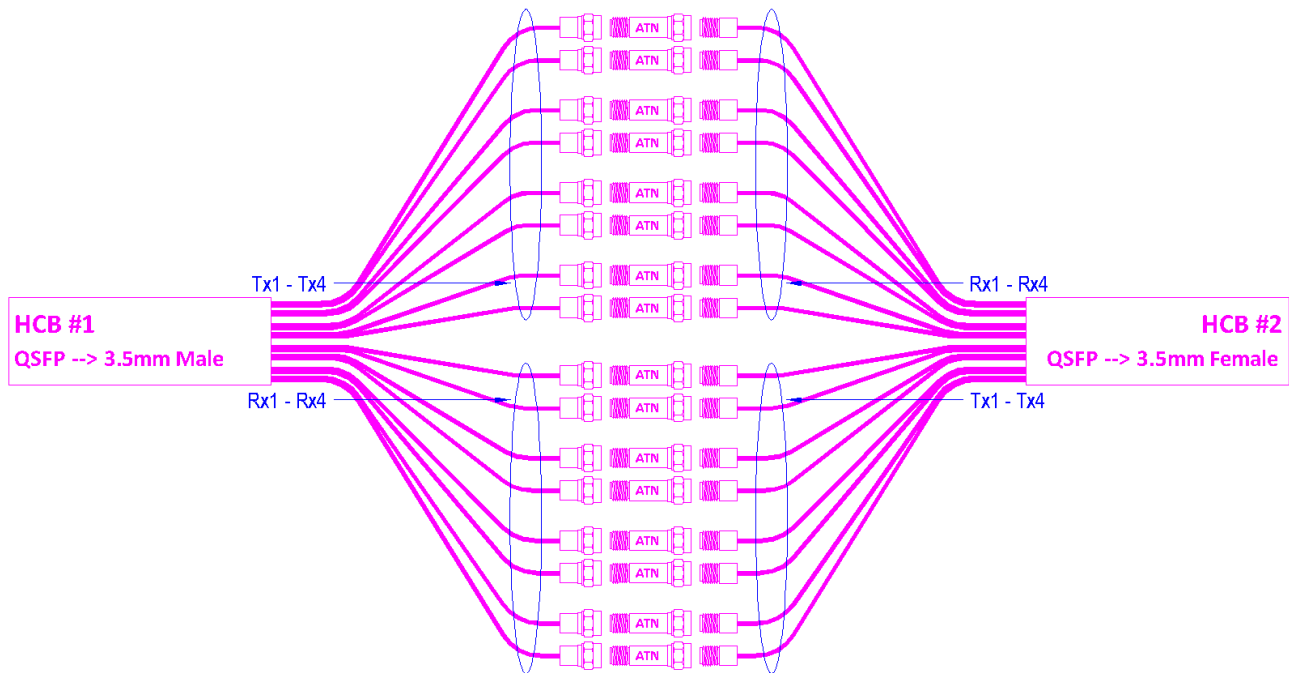

### IBTA Application:

- Wilder Dual HCBs with 10 dB Attenuators used for VNA fixture validation



**Wilder SFP28 Test fixture:**

<https://www.wilder-tech.com/en/products/datacomm/sfp-28>

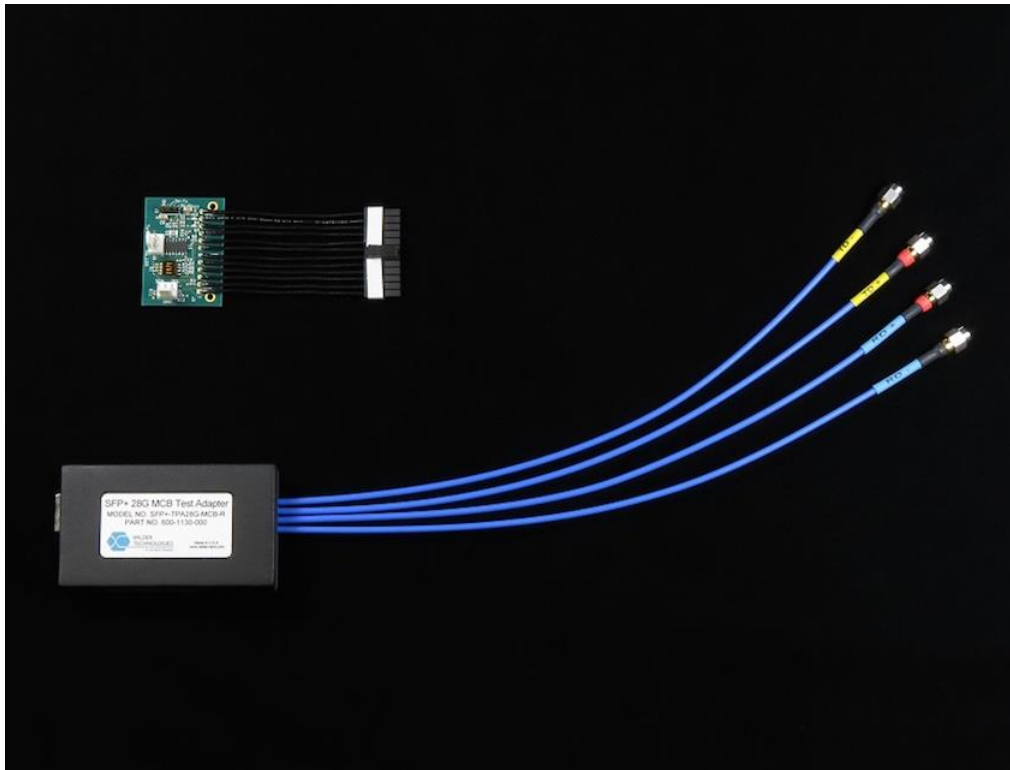

**Wilder SFP28 Module Compliance Board (MCB) and MCB Switch Module**

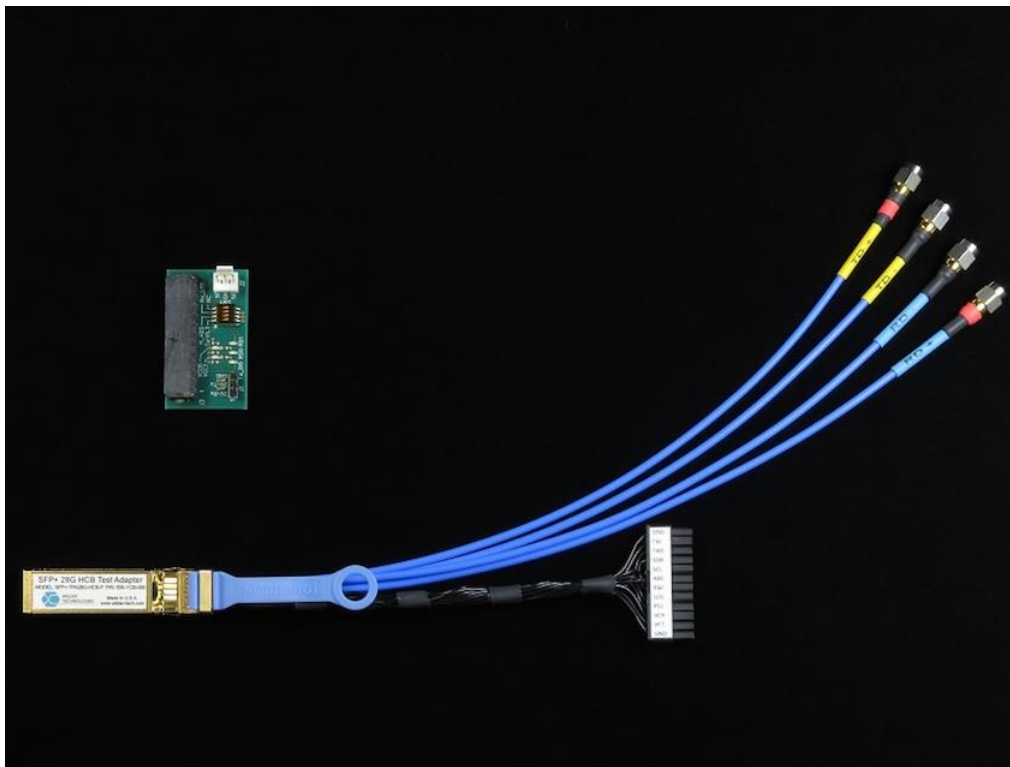

**Wilder SFP28 Host Compliance Board (HCB) and HCB Switch Module**

## Wilder SFP28 Test fixture:

<https://www.wilder-tech.com/en/products/datacomm/sfp-28>

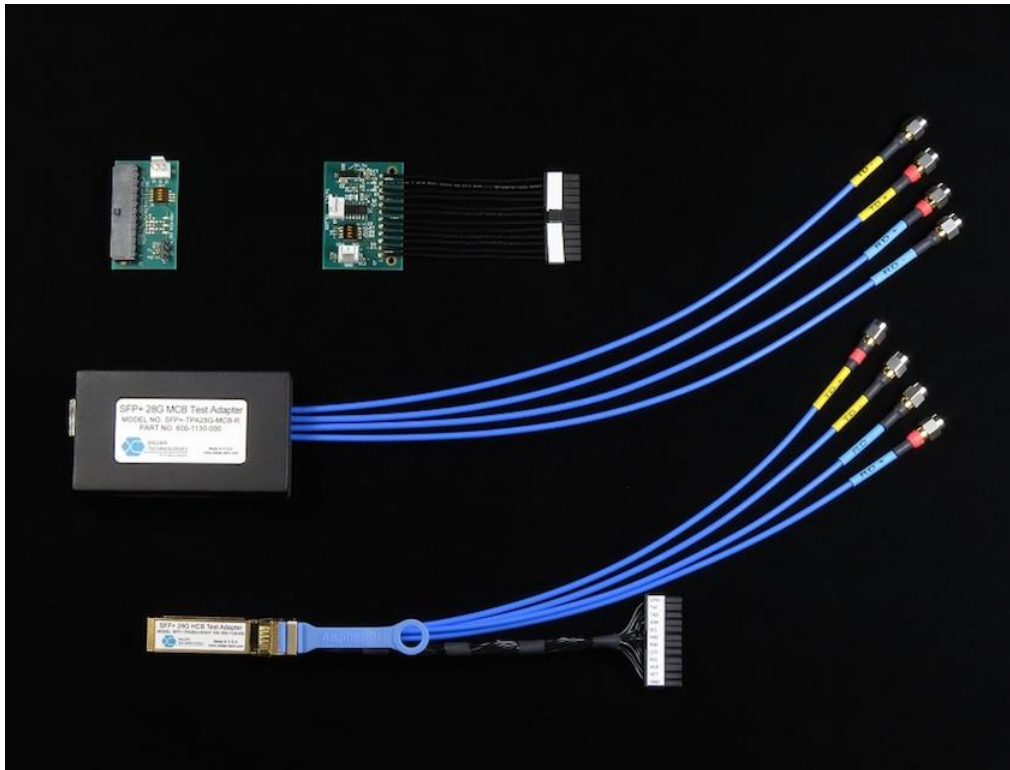

**Wilder SFP28 Module Compliance Board (MCB) / Host Compliance Board (HCB)**

### IBTA Applications:

- Wilder HCB
  - Port type 2
    - QDR, FDR, EDR and HDR device physical layer testing
    - QDR, FDR, EDR and HDR Active Cable Time Domain testing
- Wilder MCB
  - Port type 2
    - QDR, FDR, EDR and HDR Active Cable Time Domain testing
    - QDR, FDR, EDR and HDR VNA testing

**Wilder** QSFP-DD 56G fixture:

<https://www.wilder-tech.com/en/products/datacomm#qsfdd>



**Wilder** QSFP-DD 56G Module Compliance Board (MCB)

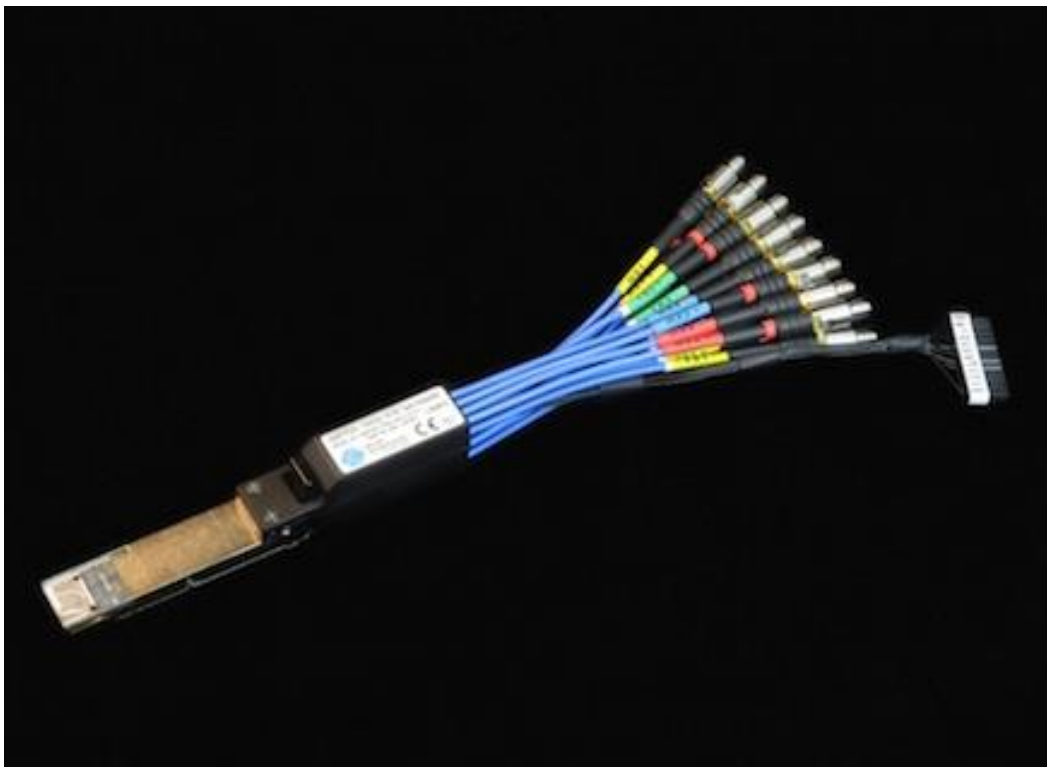

**Wilder** QSFP-DD 56G Host Compliance Board (HCB)

## Wilder QSFP-DD 112G Test fixture

<https://www.wilder-tech.com/en/products/datacomm#qsfp-dd>

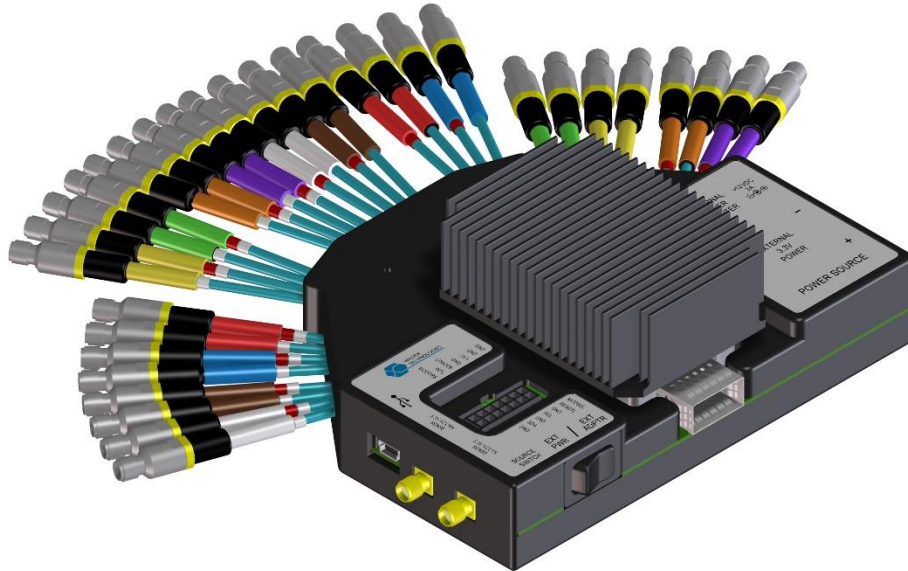

## Wilder QSFP-DD 112G Module Compliance Board (MCB)



## Wilder QSFP-DD 112G Host Compliance Board (HCB)

**Wilder OSFP 112G Test fixture:**

<https://www.wilder-tech.com/en/products/datacomm#osfp>



**Wilder OSFP 112G Module Compliance Board (MCB)**



**Wilder OSFP 112G mated Module Compliance Board (MCB) / Host Compliance Board (HCB)**



## Physical layer Test Equipment Methods of Implementation ([MOI](#))

### IBTA Active Time Domain (ATD) Testing for Cables

- [Anritsu ATD MOI for Active FDR Cables](#)
- [Anritsu Keysight ATD MOI for Active EDR Cables](#)
- [Anritsu Keysight ATD MOI for Active HDR Cables](#)

### IBTA VNA Testing for FDR and EDR Cables

- [Keysight 4 Port VNA Testing](#)
- [Keysight 32 Port VNA Testing](#)

### IBTA Testing for FDR Devices (HCAs and Switches)

- [Agilent Transmitter MOI](#)
- [Agilent-Anritsu Receiver MOI](#)

## Protocol Layer Test Equipment used in the IBTA Plugfests

### InfiniBand Protocol Analyzers

- LeCroy IBTracer 4x
  - <http://www.lecroy.com/protocolanalyzer/protocoloverview.aspx?seriesid=128>
- NVIDIA ibdump used with Wireshark
  - [http://www.mellanox.com/page/products\\_dyn?product\\_family=110&mtag=monitoring\\_debug](http://www.mellanox.com/page/products_dyn?product_family=110&mtag=monitoring_debug)
- Wireshark Network Analyzer
  - <https://www.wireshark.org/download.html>

### Software Tools to test Systems and interconnects

- Software Forge [EEPROM Memory Map](#) test suite
- Software Forge [Cable Interoperability](#) test suite
- Software Forge [Compliance Test Suite \(CTS\)](#)
  - a) IB Protocol Layer Tester
  - b) RoCE Transport Tester

### Compliance & Interoperability Testing - IBTA Integrators List

- <https://www.infinibandta.org/integrators-list/>
- This site includes a list of all the devices and cables that have passed both the Physical and Protocol Layer testing from June 2003 through May 2021.

## Information about the InfiniBand Trade Association ([IBTA](#))

- **Main IBTA Website Link:**
  - <http://www.infinibandta.org/>
- **Membership Link:**
  - <https://www.infinibandta.org/membership/>
  - <https://www.infinibandta.org/about-the-ibta/>
- **Presentations, Events and Information:**
  - <https://www.infinibandta.org/press-room/>
- **IBTA Specifications:**
  - <https://www.infinibandta.org/ibta-specification/>
  - Volume 1 – this is the protocol layer spec that covers from Layer 3 and up.
  - Volume 2 – this is the physical layer spec that covers Layers 1-2.
  - Volume 3 – this is the test specification. There are many more test documents that are only available to the Compliance and Interoperability Working Group Members (CIWG)
- **IBTA Working Groups**
  - <https://cw.infinibandta.org/workgroup/index>
  - Compliance and Interoperability Working Group
  - ElectroMechanical Working Group
  - Link Working Group
  - Management Working Group
  - Marketing Working Group
  - Software Working Group
  - Steering Committee
  - Technical Working Group
- **IBTA Roadmap:**
  - <https://www.infinibandta.org/infiniband-roadmap/>
- **IBTA Integrators' List Program:** (some links require membership)
  - Integrators' List
    - <https://www.infinibandta.org/integrators-list/>
  - IL Policy
    - <https://cw.infinibandta.org/wg/CIWG/document/8298>
  - Plugfest Information:
    - <https://www.infinibandta.org/plugfest/>
- **Test Methods of Implementation**
  - <https://www.infinibandta.org/methods-of-implementation/>